

QUESTIONS OR CONCERNS CONTACT AT:

1-800-265-1833 (English) / 1-800-567-2513 (French)

Monday through Friday 8:00 AM to 5:00 PM E .S. T.



Intertek



INSTRUCTIONS PERTAINING TO RISK OF FIRE OR INJURY TO PERSONS, READ ALL INSTRUCTIONS

IMPORTANT SAFETY INSTRUCTIONS

SAVE THESE INSTRUCTIONS

TOOLS AND MATERIALS REQUIRED:



Phillips Screwdriver



Wire Cutters



Pliers



Wrench

Wiring supplies as required by local electrical code

CAUTIONS:

To reduce the risk of fire, do not install in a compartment smaller than 12 inches by 12 inches by 12 inches.

To reduce the risk of fire, electric shock, or injury to persons:

- Use only insulated staples or plastic ties to secure cords;
- Route and secure cords so that they will not be pinched or damaged when the cabinet is pushed to the wall;
- Position the portable cabinet light with respect to the cabinet so the lamp replacement markings are able to be read during relamping;
- The National Electrical Code (NEC) does not permit cords to be concealed where damage to insulation may go unnoticed. To prevent fire danger, do not run cord behind walls, ceilings, soffits, or cabinets where it may be inaccessible for examination. Cords should be visually examined periodically and immediately replaced when any damage is noted.

SECTION 1. Parts of this Light Fixture

This light fixture comes with a 6' Power Cord with a polarized plug (one blade wider than the other) as a safety feature. This plug can be used in a polarized outlet only one way. If the plug does not fit fully in the outlet, reverse the plug. If it still does not fit, contact a qualified electrician. Never use with an extension cord unless the plug can be fully inserted. Do not alter the plug.

(See Figure1.)

- Mounting holes go through light fixture to make it easy to locate where to drill a pilot holes for screws or for plastic anchors (not included) if installing in drywall.

-On/Off switch.

-Screw Plugs to cover screws for a clean installation.

-Input Panel Cover can be removed to plug in 6' Power Cord for connection to 120V polarized outlet. The 12" Linking Cord is used to link fixtures together. The Output Panel Cover can be removed to plug in the other side of the 12" Linking Cord to link fixtures together. (See Figure2.)

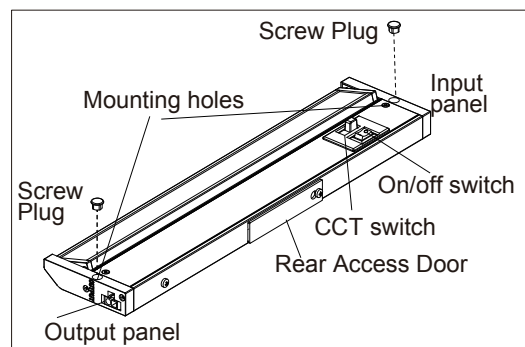

Figure1

Placement of Fixture

Determine location for connecting to nearest 120V polarized receptacle. (Note: before mounting to cabinet be sure fixture is within 6' of an electrical outlet, considering path cord will take to be neatly and securely mounted to cabinet and wall.) **If you are not sure about this installation consult a local licensed electrician or electrical contractor before proceeding.**

PACKAGE CONTENTS

PART	DESCRIPTION	QTY
A	LED under cabinet light	1
B	Mounting screw	2
C	12" Linking Cord	1
D	6' Power Cord	1
E	Screw Plug	2
aa	Wiring Compartment Cover	1
bb	Rear Access Cover	1
cc	Strain Relief	1

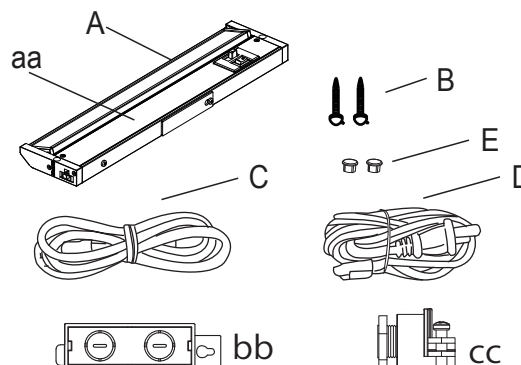

QUESTIONS OR CONCERNS CONTACT AT:

1-800-265-1833 (English) / 1-800-567-2513 (French)
 Monday through Friday 8:00 AM to 5:00 PM E.S.T.



SECTION 2. Plug-in Fixture Installation

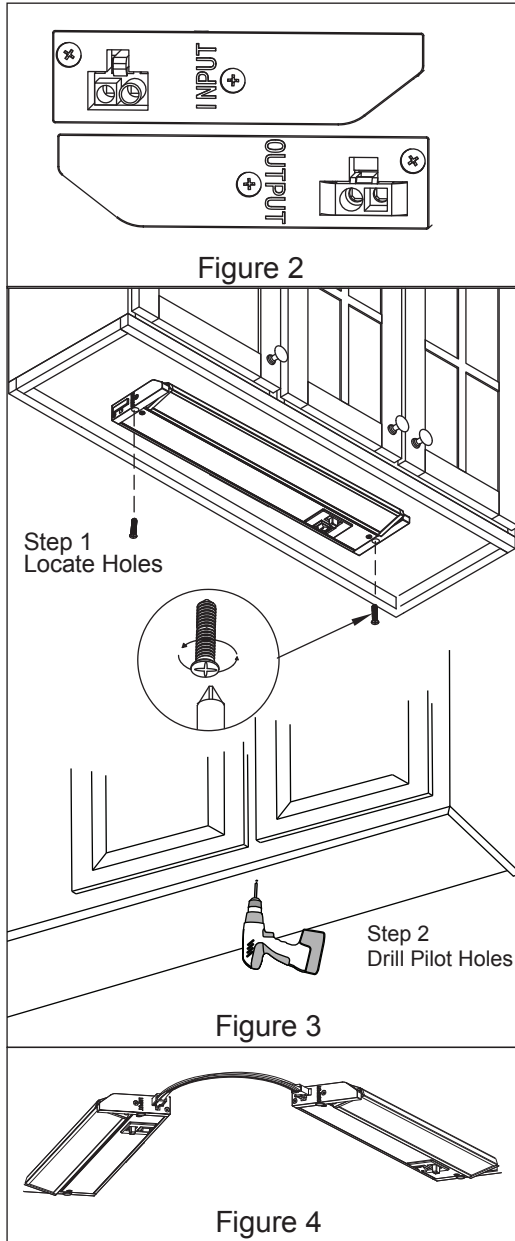

1. **Locate Mounting Holes:** Place fixture on mounting surface and with a thin screwdriver, pencil or scratch awl mark the spot where the screws will be located through the Mounting Holes in the top of the fixture. (See Figure 3.) Do the same for a multiple fixture installation. When mounting into drywall, drill 3/16" holes for the plastic Wall anchors (not included). Insert the plastic wall anchors into the proper holes and tap them into place so they are flush with the surface of your drywall. For mounting into wood cabinets drill 1/16" pilot holes, 1/2" deep. **Caution: Check your cabinet thickness first. Be careful not to drill through cabinet.**

Prepare fixture for installation by turning screws provided into mounting holes in the top of the fixture. Ensure they protrude through the back of the fixture about an 1/8". This will help you line up screws to mounting holes.

2. Attach fixture to cabinet or wall by tightening screws securely. Insert screw plugs for a clean installation. Connect 6' Power cord to the Input port after removing Input Panel Cover. (See Figure 2.)

3. Plug in Power Cord to a 15AMP circuit grounded outlet. **Warning:** Do not conceal power supply cord inside a wall, ceiling, soffit, kitchen cabinet, or similar permanent structure.

Do not run the power supply cord through holes in walls, ceilings or floors. Use UL listed cable staples (not included) to route power cord to bottom of cabinet and wall for a clean installation.

4. Interconnecting Multiple Fixtures

WARNING: In multiple fixture installations do not electrify fixture group until all electrical connections have been made and fixture have securely mounted.

UCL-54 Series fixtures may be interconnected using either the 12" Linking Cord supplied with this kit. (See Figure 4) Follow instructions above for Plug-in Fixture Installation.

First mount fixture that receives incoming electrical supply. Remove the input or output panel covers as needed. Make sure the Linking Cord on both ends are fully inserted in to ports on both fixtures. There should be some slack in the Linking Cord so that the electrical connectors are not stressed in any way. Use cord clips (not included) to keep cord safely attached to mounting surface.

Compatible wall dimmers : Leviton # 742-66EV-P0W, 742-6672-HLW, 722-6674-PDW, Lutron # SCL-153PH-WH

UCL-54-10: Max # of Lamps per 150W Dimmer: 30 pcs

UCL-54-20: Max # of Lamps per 150W Dimmer: 15 pcs

UCL-54-30: Max # of Lamps per 150W Dimmer: 10 pcs.

QUESTIONS OR CONCERNS CONTACT AT:
 1-800-265-1833 (English) / 1-800-567-2513 (French)
 Monday through Friday 8:00 AM to 5:00 PM E.S.T.



SECTION 3. Hardwire Fixture Installation

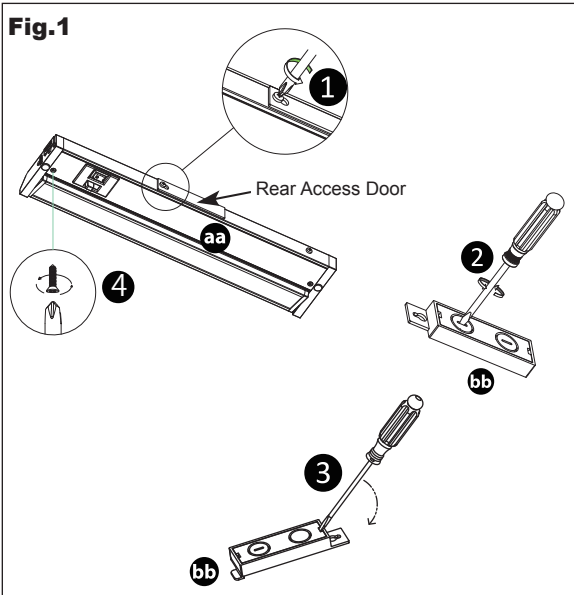

1. Prepare the light for installation. (See Fig.1)

Remove the Rear Access Door by loosening the locking screw and slide the keyhole slot over the screw head, until it reaches to the large end of the keyhole slot.

Push it into the slotted hole, press and turn clockwise for about 45 degrees, the knockout cover should come off easily. Carefully remove the knock-out by using a flat head screwdriver.

Remove Cover of Wiring Compartment Cover (aa) by removing screws at each end.

2. Install the Strain Relief. (See Fig.2)

Remove the Locknut from the Strain Relief (cc), then push the Strain Relief (cc) into the knockout hole on the Rear Access Cover (bb) and screw clockwise to lock it in place with locknut.

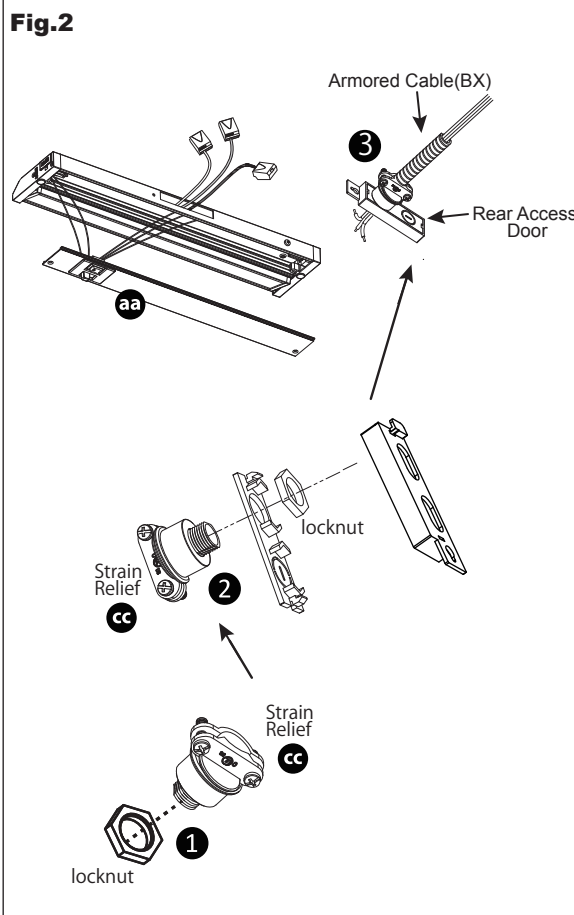

Note: To ensure that light is installed seamlessly under the cabinet, the strain relief needs to fit a bit loosely in the knockout hole. Simply put, position strain relief with screw heads on it facing downward when installed on fixture. It allows you to tighten/loosen the clamp screws after the fixture has been attached to the mounting surface.

Insert the armored cable through the Strain Relief (cc) and tighten the clamp until it is secure. Allow enough wire length to make the connection.

QUESTIONS OR CONCERNS CONTACT AT:
 1-800-265-1833 (English) / 1-800-567-2513 (French)
 Monday through Friday 8:00 AM to 5:00 PM E . S. T.

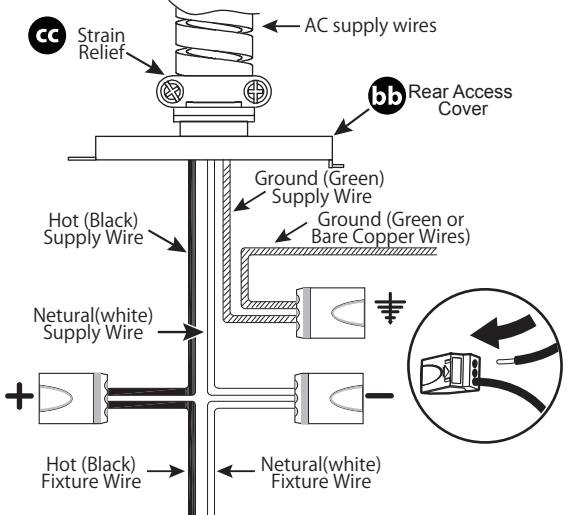
Fig.4

3. Connecting the wires. (See Fig.4)

Pull 3 wires out of the fixture to allow connection to the branch circuit. Wire nuts suitable for #12-24 AWG solid core wire. Strip back jacket on AC supply wires 3/8" and use push-in wire connector to connect wires (BLACK to BLACK, WHITE to WHITE and GREEN to GREEN/BARE COPPER).

WARNING: DO NOT MIX WIRES OR CHANGE POLARITY.

Note: If removal of supply wire is required, twist and pull until wire releases. Do NOT attempt to remove pre-installed, fixture wiring.

Ensure the connectors are spliced tightly and carefully push the spliced wires back into the wire compartment.

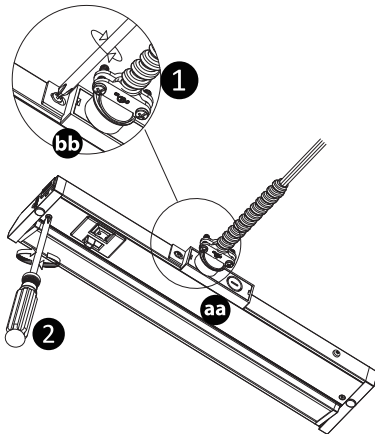
Fig.5

4. Attach the Rear Access Cover to the fixture.

Attach the Rear Access Cover (bb) by reversing the removal instructions of Rear Access Door.

To re-attach the Wiring Compartment Cover (aa), tuck all the wires into the wiring compartment, then place the Wiring Compartment Cover (aa) to the fixture and attach with two screws.

WARNING: ENSURE ALL THE WIRES AND CONNECTIONS ARE SEALED PROPERLY INSIDE THE FIXTURE WITHOUT "PINCHING" ANY WIRES.

Turn on the electricity at the circuit breaker or fuse box.