

EASY CONNECT™ INSTALLATION INSTRUCTIONS

ICW1161A01
IT1161A
12/23

NEED HELP?
Call or Email us first

Our service team is ready to answer your questions...
1-800-265-1833 (English) / 1-800-567-2513 (French)
IN CANADA - ressaiescanada@canarmna.ca - IN USA - ressaiesusa@canarmna.ca

Monday – Friday
8 AM - 5 PM EST.



INSTRUCTIONS PERTAINING TO RISK OF FIRE OR INJURY TO PERSONS
READ ALL INSTRUCTIONS

**IMPORTANT SAFETY
INSTRUCTIONS**
SAVE THESE INSTRUCTIONS

TOOLS AND MATERIALS REQUIRED:



Phillips
Screwdriver



Wire Cutters

SAFETY PRECAUTIONS:

1. TURN OFF ELECTRICAL POWER BEFORE STARTING INSTALLATION OF LIGHT FIXTURE.
2. WIRING SUPPLIES AS REQUIRED BY LOCAL ELECTRICAL CODE.
3. THIS PRODUCT MUST BE INSTALLED IN ACCORDANCE WITH THE APPLICABLE INSTALLATION CODE BY A PERSON FAMILIAR WITH THE CONSTRUCTION AND OPERATION OF THE PRODUCT AND THE HAZARDS INVOLVED.
4. TO CLEAN THE FIXTURE, TURN OFF THE POWER, WAIT FOR IT TO COOL, AND WIPE THE FIXTURE WITH A CLEAN, SOFT CLOTH.

NOTE: Product may not look exactly as shown in figures.

INSTALLATION:

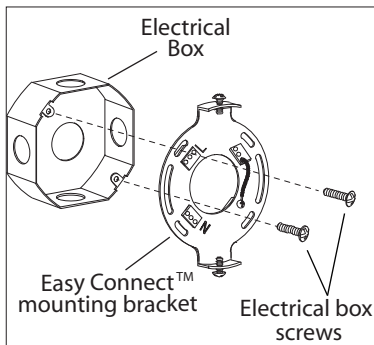

1. Attach Easy Connect™ mounting bracket to electrical box with electrical box screws (not included).

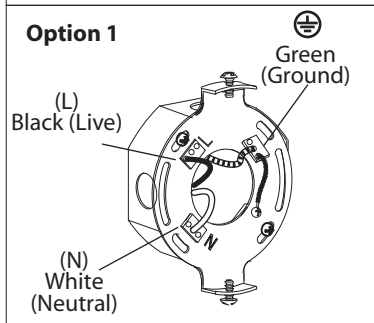

2. **Option 1:** Connect (push) electrical wires from electric box (house wiring) into correct inserts.

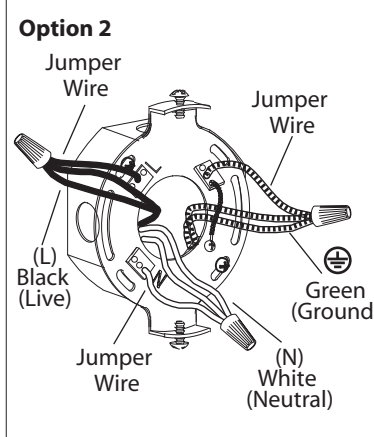

2. **Option 2:** For multiple green (ground), black (live) and white (neutral) wires joined in the electrical box (house wiring), attach a single "green," "black" and "white" jumper wire before connecting. Strip 7mm from the 6" jumper wires supplied. Then connect (push) wires into the correct inserts.

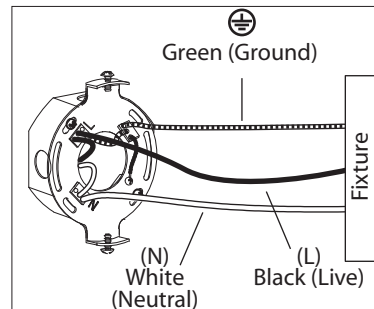

3. Connect (push) electrical wires from fixture into correct inserts.

4. Once connections of wires are completed, carefully tuck wires and wire nuts into the electrical box making sure no bare wire (on the black and white) is visible at the wire nuts.

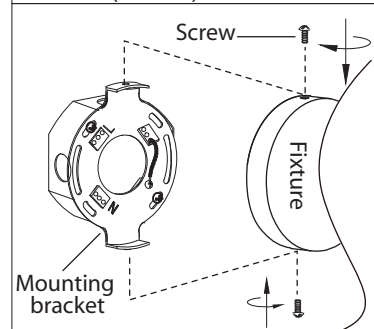

5. Attach fixture to mounting bracket by tightening the 2 screws.

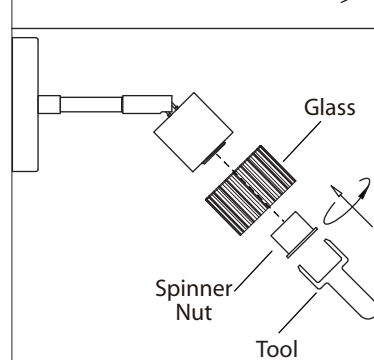

6. Remove spinner nut from socket. Position glass on lamp and secure with spinner nut. **(Please check the glass before installing for any cracks. Do not overtighten the spinner nut to attach the glass to the fixture.)**

7. Install proper bulb type and wattage (not included).

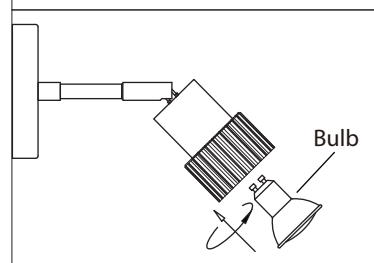

WARNING

Warning - HOT :
Do not touch any metal surface.